



# RENEWABLE ENERGY TECHNOLOGIES

## SYSTEM FOUNDINGS MODULE

2022-2-TR01-KA210-VET-000098216

### IN RENEWABLE ENERGY TECHNOLOGIES NEW APPLICATIONS ACCORDING TO 4.0 STANDARDS



Co-funded by the  
European Union

*"The European Commission's support for the production of this publication does not constitute an endorsement of the contents, which reflect the views only of the authors, and the Commission cannot be held responsible for any use which may be made of the information contained therein."*



This learning material was prepared within the scope of the New Applications in Renewable Energy Technologies According to 4.0 Standards project numbered 2022-2-TR01-KA210-VET-000098216. It is intended to guide vocational education trainers. It is free for users, cannot be sold or reproduced. It will be published as an e-book on the Project Website (<http://www.renewableenergy40.com>)

## DESCRIPTIONS

<b>FIELD</b>	<b>Renewable Energy Technologies</b>
<b>OCCUPATION</b>	<b>Solar Energy Systems</b>
<b>NAME OF THE MODULE</b>	<b>System Groundings</b>
<b>DESCRIPTION OF THE MODULE</b>	This module is a learning material that provides information about grounding the solar panel system.
<b>COMPETENCE</b>	Installing grounding systems of solar panels
<b>PURPOSE OF THE MODULE</b>	<p><b>General purpose</b> When the necessary environment and equipment are provided, you will be able to make grounding connections between panels and main grounding line.</p> <p><b>Purposes</b></p> <ol style="list-style-type: none"> <li>1. You will be able to make grounding connections between panels with appropriate tools.</li> <li>2. You will be able to connect the main grounding line with appropriate tools.</li> </ol>

# 1. GROUNDING OF PANELS

## 1.1. Grounding, Grounding Types and Equipment

One of the most effective measures to protect human life and some devices in energy production, transmission and distribution networks is grounding. Grounding is the connection of all installation parts that are not under voltage with suitable conductors to a conductive object (electrode) placed in the soil mass. The purpose of grounding is to ensure the safety of those who use electrical receivers and to prevent damage to the devices. The bodies of all electrical machines, metal parts of pipes, metal parts of tables and the like must be grounded.

Grounding types; It is divided into four: protective grounding, operational grounding, grounding against lightning and functional grounding. (Figure 1.1).

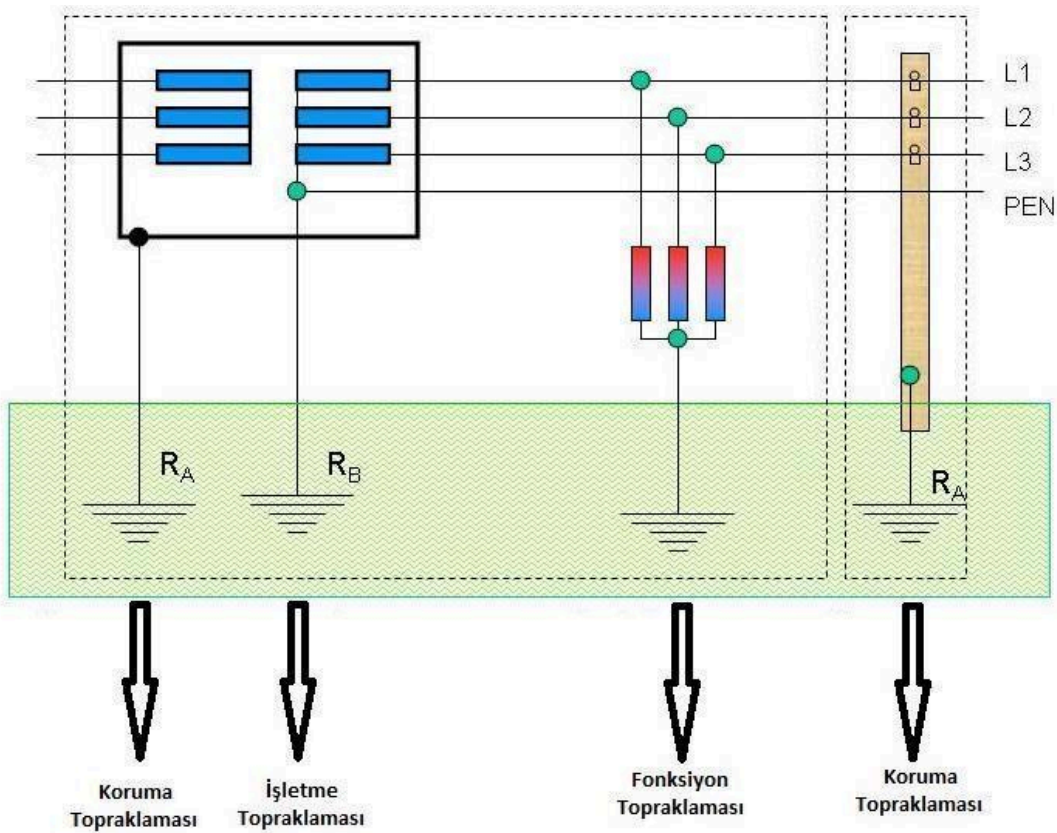

Figure 1.1: Grounding types

Protection grounding: Grounding of inactive parts of operating vehicles to protect people against dangerous touch voltages. It is the direct connection of conductive installation parts that are not under voltage to grounders or grounded parts in order to ensure that the electrical circuit is opened with overcurrent protection devices in case of an insulation fault.

Operational grounding: It is the grounding of the operating current circuit for normal operation of the facility. It is done by grounding the zero points of transformers in low voltage networks, and by grounding a pole or center conductor in direct current facilities. In this way, it is tried to ensure that the voltage against the ground in the system does not exceed certain values. Operational grounding in medium and high voltage networks varies

according to country regulations. In our country, medium voltage networks are grounded through resistance. Direct grounding of high voltage networks is preferred.

**Grounding against lightning:** Lightning is the rapid discharge of electrical charges between the cloud and the ground. Lightning occurs when the energy at the bottom of a cloud reaches a sufficient level (10kV/cm<sup>2</sup>) and is activated as a beam of electrons towards the ground. In the event of a lightning strike, it is the grounding of conductive parts that are not related to the operating current circuit in order to prevent jumps to conductors that are under voltage due to operational requirements and to transmit the lightning current to the ground.

For example, protection conductors of overhead lines, metal or concrete poles are grounded through a special grounder. This is called lightning grounding. Lightning grounding is also a kind of protection grounding and for this reason, two groundings are connected to each other. The purpose of lightning grounding is to both transmit the overvoltage wave caused by a lightning strike to the electrical facility to the ground without damaging the operating vehicles, and to render harmless the lightning striking the buildings by throwing it into the ground without harming human life or causing a fire.

**Functional grounding:** It is the grounding performed to ensure that a communication facility or an operating element fulfills the desired function. Functional grounding also carries the operating currents of communication devices that use ground as a return conductor. It is grounding performed to ensure that a facility or an operating element can perform the desired function. Protection against lightning effects, rail system grounding, grounding of low current devices, radio communication systems are the best examples of this type of grounding.

Grounding is also done against static electricity. Static electricity can be thought of as the energy released when electrons move between atoms. Lightning is the biggest example of static electricity. In short, static electricity is the electrical energy that occurs as a result of the friction of a solid against a solid, a liquid against a solid, or two liquids against each other, which is generally useless and discharged from time to time in the form of arcs. This uncontrolled power is a very important cause of fire. In industrial and commercial processes, static electricity is of great importance due to the risk of fire. Static electricity in industrial and commercial processes; It is seen in many places such as transportation works, conveyor belts, coating processes, covering and filling processes, printing and printing processes, mixing processes and spray applications.

Grounders (grounding electrode), grounding conductors and connection parts are used in the construction of grounding facilities. Strip, profile (bracket), plate and braided conductive grounding elements are produced in accordance with the "Grounding Regulations in Electrical Facilities" published by the Ministry of Energy and Natural Resources.

**Grounding electrode:** Conductive parts that are buried in the ground and have a conductive connection with the ground, or are buried in concrete and have a large surface connection. Grounders by location:

**Superficial grounder:** It is a grounder that is generally placed at a depth of 0.5-1 m. It can be made of galvanized strip or round or stranded conductor. It can be a star, ring, eyed grounder or a mixture of these.

**Deep grounder:** It is a grounder that is generally placed vertically deeper than 1 m. It can be made of galvanized pipe, round bar or similar profile materials.

The following elements can be used as grounders:

- o Strip or braided conductor grounding (Picture 1.1)
- o Rod grounder or profile (angle bar) grounder (Picture 1.2)
- o Plate grounder (Picture 1.3)



**Picture 1.1: Strip grounder**



**Picture 1.2: Rod grounder**

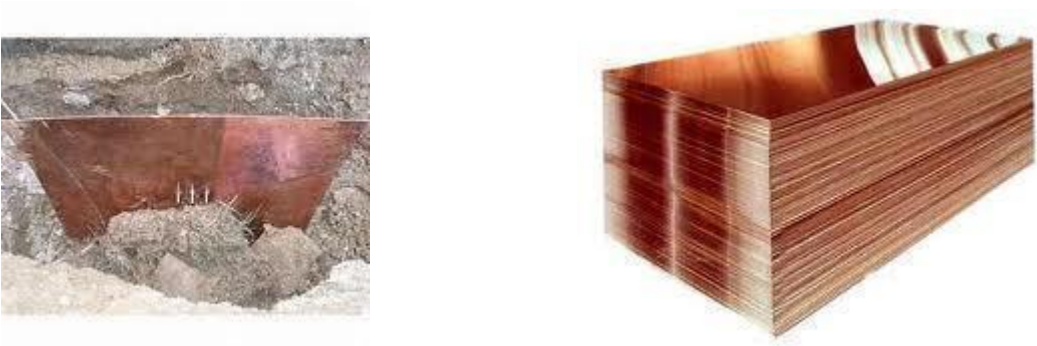

**Picture 1.3: Plate grounder**

Since grounding electrodes are in constant contact with the soil, they must be made of material resistant to corrosion (chemical and biological effects, oxidation, electrolyte, corrosion

formation and electrolysis, etc.). These must be resistant to mechanical stress that may arise during installation, and must also withstand mechanical effects that occur in normal operation. Steel and steel piles or other grounders embedded in the concrete foundation can be used as part of the grounding facility.

**Connection elements:** Consists of terminal blocks, shoes and other auxiliary connection elements. It is made of copper and galvanized. (Figure 1.4).



**Picture 1.4: Grounding fasteners**

### **1.2.Measurement of grounding resistance**

Grounding resistance (soil resistance) is the reaction of the soil when it can pass electric current. Earth is actually a weaker conductor than conductors such as copper. However, if the area for the current is large enough, the resistance is low and the ground can become a good conductor. For this reason, there is a resistance that must exist between the conductors in the system and the ground. These measurements are made before the facility is established, and the installation is carried out after the necessary calculations and preparations.

Resistivity (specific resistance) of the soil is the resistance of 1 m<sup>3</sup> of soil. Its value depends on the structure of the soil and the water content in it. The transition resistance of an electrode to soil depends on the resistivity of the soil.

The insulation of each conductor against the ground is measured with an earth resistance tester (soil megger) and the insulation of conductors against each other is measured with an insulation tester (insulation megger). In short, all insulation resistance measuring devices (meggers) are specially produced portable ohm meters.

#### **Theoretical Principle of Grounding Measurement**

The first theoretical measurement logic and calculations of measurements made with soil megger were made by Dr. Frank Wenner from the US Standard Bureau. Frank Wenner made it in 1915. Classic type soil meggers have three electrodes: E, P and C (Figure 1.5).

E: Earth electrode

C: Current electrode

P: Potential electrode

Users obtain the potential difference between E and P by applying constant current to electrodes E and C. The device gives the ground resistance R by calculating  $V/I$ .

### Measurement of Grounding Resistance (Earth Resistance)

The most common method is the 2-pile (3-probe) measurement method. Electrodes P and C are driven deep into the ground. The distance between these electrodes should be 5-10 m. The green wire connects to the ground busbar. This bus must be separated (Figure 1.2).



Resim 1.5: Megger measuring instrument

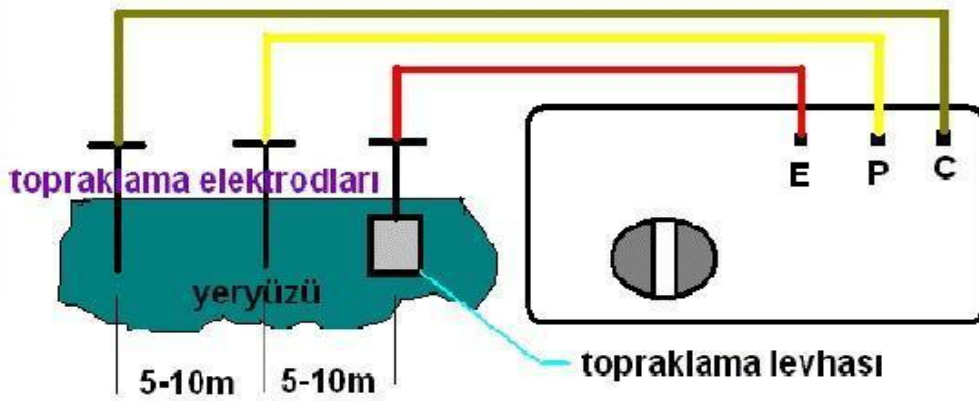

Figure 1.2: Meger connection type

The yellow wire is connected to the potential electrode (P), and the red wire is connected to the current electrode (C). The fact that the soil into which the electrodes are driven is moist ensures that the piles can be driven easily and the soil resistance is lower. If the soil is dry, moistening can be provided by pouring water (Photo 1.6).





**Photo 1.6: Meger pile connection and resistance measurement**

### **1.3. Interpanel Grounding**

All module frames must be properly grounded in countries where module grounding is mandatory. Equipment designated for grounding the metallic frames of PV (Photo Voltaic) modules must be connected to ground the exposed metal frames of the module. Ground screws, bolts or other parts must be used separately from the module mounting parts.

Photovoltaic systems that produce renewable energy carry the risk of lightning strikes due to the location and installation area. Protection of buildings and photovoltaic systems is important in terms of increasing the operating time of the facilities and the safety of investments. Solar panels are grounded with solid copper and flexible copper conductors depending on the installation location.

The biggest factor in the failure of photovoltaic systems is generally high voltage caused by lightning strikes. In such cases, the user of the photovoltaic system faces high repair costs as well as the damage caused by the system stopping. To prevent these damages, lightning and high voltage protection designed to suit each other should be used.

Since the metal frames of the solar panels are on the solar panel stand mounting rail, grounding the solar panel mounting rails will also ground the solar panels (Figure 1.3).



*To play the video, click on the image or click the link below and open it with your browser.*

<https://www.youtube.com/watch?v=QQ7yelPx8wU>



To play the video, click on the image or click the link below and open it with your browser.  
<https://www.youtube.com/watch?v=0Q15sns0Fug>

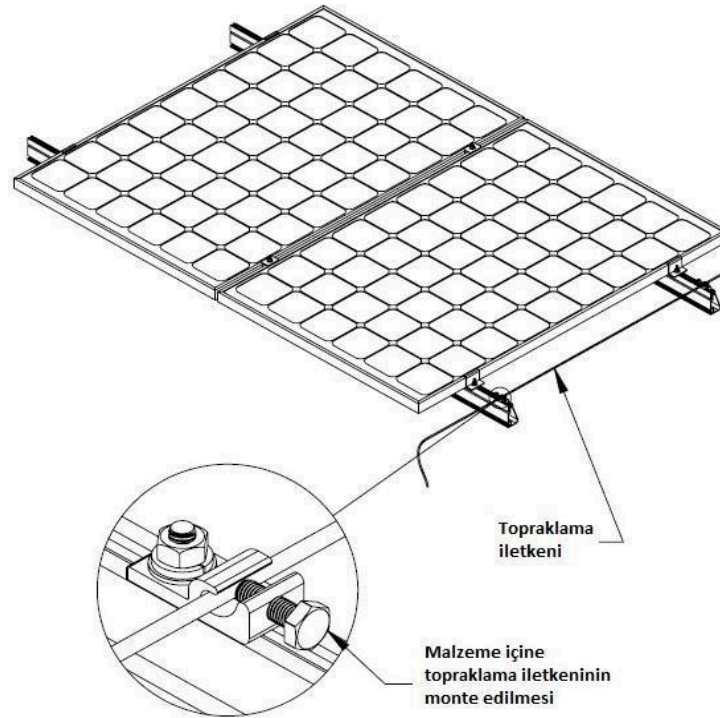

Figure 1.3: Connecting the grounding conductor to solar panels

#### 1.4. Grounding Between Panels and Solar Stand

Since the application areas of photovoltaic systems are always designed to cover the entire available surface, they must be integrated with the existing TT grounding system. In the

TT grounding system, protection grounding is done next to the receiver, only phase and neutral wires are pulled to the transformer.

Solar panels are mounted on metal mounting rails. Since the metal frame of the solar panels and the mounting rail are conductive and in contact with each other, grounding the solar panel mounting rail will also ground the solar panel. The joints of the solar panel mounting rails must also be electrically connected (Figure 1.4).



*To play the video, click on the image or click the link below and open it with your browser.*  
[https://www.youtube.com/watch?v=DduaXytIN\\_U](https://www.youtube.com/watch?v=DduaXytIN_U)

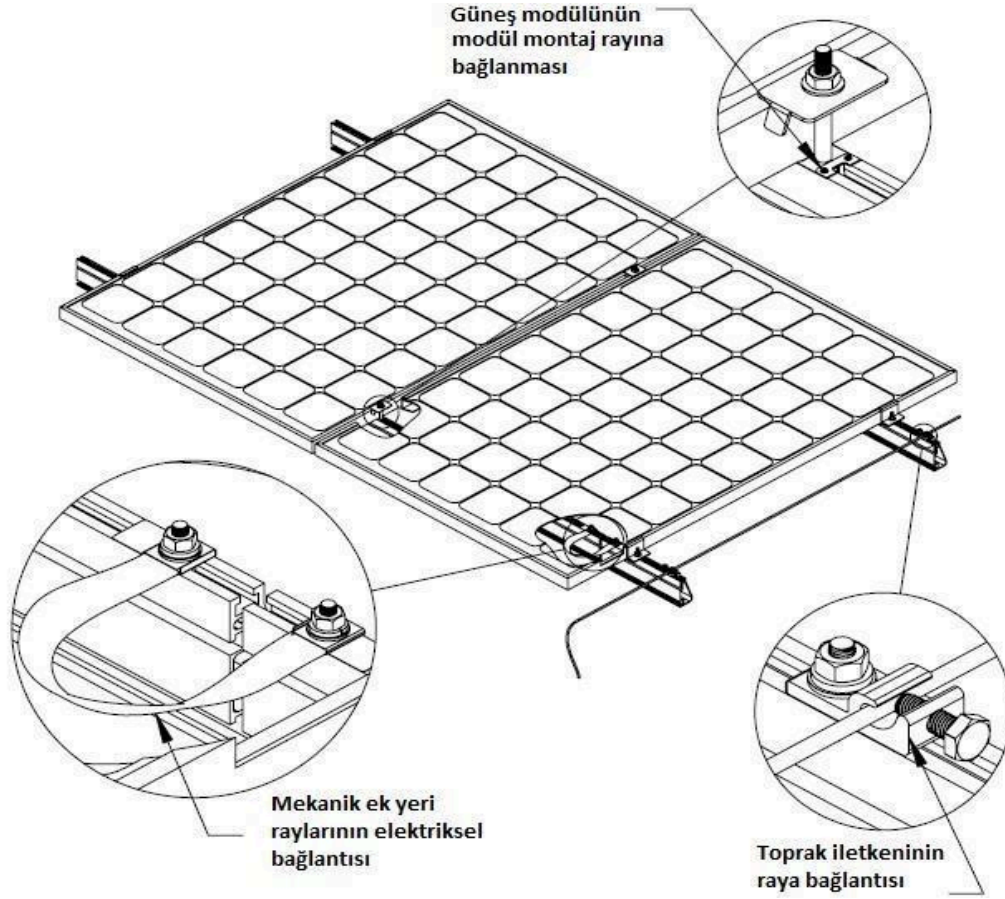

**Figure 1.4: Connection of solar panels to the mounting rail**

Solar panels are grounded with solid copper and flexible copper conductors, depending on the mounting location, as shown in the applications below (Picture 1.7).



**Picture 1.7: Grounding of solar panels in open areas and buildings**

## 2. SOLAR STAND GROUNDING

### 2.1. Driving Grounding Rods

If local conditions do not require the use of another material, it is best to use hot galvanized steel, copper-plated steel or copper as a grounding device. The connection conductor to the grounding electrode is made of copper or galvanized conductor in the form of round, braided or flat sheets of various thicknesses (Figure 2.1).

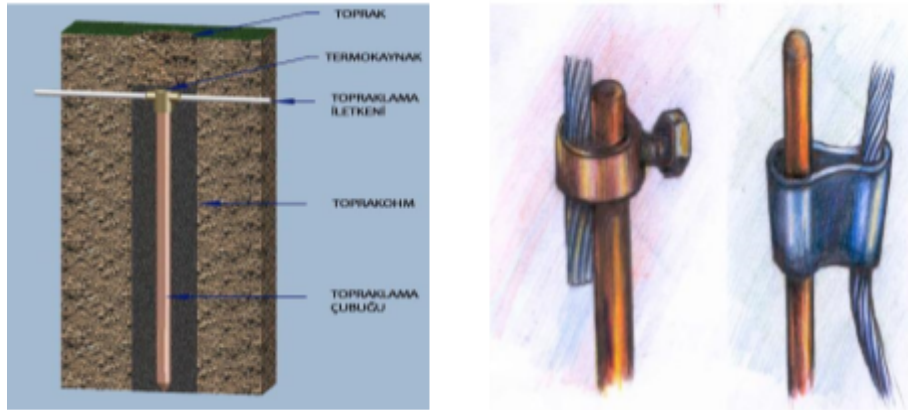

Picture 2.1: Connection of the conductor to the ground rod in the ground

The smallest cross-section of grounding conductors is according to the Electrical Installations Grounding Regulation,

- Copper 16 mm<sup>2</sup>
- Aluminum 35 mm<sup>2</sup>
- Steel should be 50 mm<sup>2</sup>.

A good grounding rod should have low electrical internal resistance and its cross-section should be sufficient to carry high currents. It must have high mechanical strength, have a solid center for easy hammering, and be durable and resistant to corrosion.

The connection of the grounding rod and the grounding conductor is provided by the terminal system. In bars where there is no terminal system, connection is made to the welding system from the top of the bar. If the connection is made with a terminal system, the connection point is protected with tar or a similar substance. Grounding rods, selected in appropriate sizes and in a number that will provide the desired grounding resistance, should be driven into the ground vertically and with the upper end at least 80 cm below the soil. Rod grounders should be preferred especially in places where specific soil resistance decreases with depth. In cases where more than one rod is driven, the distance between two rods will be at least twice the length of the rod. The sticks will be driven into the ground firmly but in a way that does not loosen the surrounding soil. Rods will not be placed in pre-drilled holes. If it is necessary to drill a hole, sifted field soil or clay soil will be placed around it after the rod is placed.

Grounding is done with at least two or three rods, usually between 12.5 mm and 40 mm in diameter and at least 1.20 m long, driven vertically into the ground. In our country, two-piece

copper or steel-copper electrodes with a diameter of 20 mm and a length of 3 m or 3.5 m are generally used. Rods can be spliced together for larger lengths. Grounding rod length is more important than the diameter of the rod. The spacing of grounding rods should be twice as long as the rod length and, if possible, in a crow's foot shape (Picture 2.2).



**Figure 2.2: Crow's foot grounding system**

Grounding rods should be connected to each other with down conductors at least 10-15 cm below the soil surface. This is because the soil surface can freeze up to 5 cm in winter. Grounding rod and grounding conductors can be connected in two ways:

**With thermowelding:** Copper oxide is placed in a graphite mold and ignited. As a result of the combustion, the grounding rod and the grounding conductor become fused together. This method is not recommended due to errors made in applications.

**With additional terminal:** The grounding rod and down conductors are tightened thoroughly with the additional terminal with good wall thickness and only bitumen, oil paint, etc. are applied to the joint. By applying it, it is protected from oxidation and corrosive effects that will prevent transition resistance.

The grounder must have good contact with the surrounding soil. Good conductive soil layers should be used in the installation of grounders. If the soil layers are dry, the soil around the grounder should be wetted and turned into mud, and after the grounder is buried, the soil should be pounded and compacted. Stones and large gravel next to the grounder should be removed as they will increase the spreading resistance. The propagation resistance of strip and rod grounders depends more on their distance and less on their cross-section.

## **2.2. Pulling Grounding Cables**

The grounding cable drawn from the copper plate or grounding conductor to the building is generally yellow-green in color, and its cross-section should be half or more than half of the cross-section of the neutral line drawn to the building. For example, if the supply cable entering the building is  $3 \times 50 + 35 \text{ mm}^2$ , the neutral line is  $35 \text{ mm}^2$ . Half of this should be the grounding conductor cross-section of  $16 \text{ mm}^2$  or  $25 \text{ mm}^2$ , which is the larger of the two. This is how it is done in practice. When drawing the grounding cable, attention should be paid to mechanical stresses. It should be easily accessible for protection against corrosion in laying wall transitions and pans, and should be protected against chemical effects. The protective grounding resistance should be less than 10 ohms.

Grounding conductors should be connected in the shortest possible way. Grounding conductors should be protected against mechanical damage. Grounding conductors can be placed

on the ground. In such a case, they can be reached at any time. If there is a risk of mechanical damage, the grounding conductor should be protected appropriately. Grounding conductors can also be buried in concrete. The connection ends should be easily accessible at both ends. Special care must be taken to prevent corrosion where bare earthing conductors enter the ground or concrete. When splicing earthing conductors together, the splices must have good electrical continuity to prevent “unacceptable heat build-up” in the event of a fault current. The splices must not be loose and must be protected against corrosion (Figure 2.3).



Picture 2.3: Connecting the grounding conductor to the grounding rod

### 2.3. Making Grounding Connections

Appropriate fittings must be used to connect the grounding conductor to the grounder, the main grounding terminal, and any metallic parts. If the bolt connection is made with only one bolt, at least M10 bolt should be used. Sleeve connections such as crushed, compressed or screwed connections can also be used in stranded conductors. Lead sheaths of stranded copper conductors should be stripped at the connection points. Connection points must be protected against corrosion (e.g. with materials such as bitumen). It should not be possible to disassemble the attachments without using special tools (Figure 2.4).



Picture 2.4: Grounding fasteners

## REFERENCES

- Eshia Enerji SL. (2024). *Training notes*. Eshia Enerji SL. <https://www.eshia.es/>
- N2 Anima GmbH. (2024). *Training notes*. N2 Anima GmbH. <https://n2anima.com/>
- European Commission. (2024). *Photovoltaic Geographic Information System*. [https://re.jrc.ec.europa.eu/pvg\\_tools/en/tools.html](https://re.jrc.ec.europa.eu/pvg_tools/en/tools.html)
- Kıvanç Solar Panel Production Facility. (2024).
- Keçel, S. (2007). *Development of a model for meeting household electricity needs with solar panels in different regions of Turkey* (Master's thesis, Gazi University, Institute of Science).
- Ewing, R. A. (2003). *Power with Nature: Solar and Wind Energy Demystified* (1st ed.). Pixyjack Press.
- Foley, G. (2005). Photovoltaic energy: Applications in rural areas of the developing world. In A. Kandemir (Ed.), *Turkey Development Bank A.Ş.* (pp. 10-42). Ankara.
- Gilbert, M. M. (2004). *Renewable and Efficient Electric Power Systems*. John Wiley & Sons.
- Güven, S. Y. (2006). An example application of solar cell-assisted environmental lighting and irrigation systems. *Engineer and Machine*, 548, 46-48.
- Quaschnig, V. (2005). *Understanding Renewable Energy Systems*.
- Köroğlu, T., Teke, A., Bayındır, K. Ç., & Tümay, M. (n.d.). *Design of solar panel systems*. Çukurova University, Department of Electrical and Electronics Engineering.
- Solargis sro. (2024). *Solargis sro*. <https://solargis.com/>
- Electrical Engineers Chamber Mersin Branch. (2019). *GES Brochure*.
- Ceylan, İ., & Gürel, A. E. (2022). *Solar Energy Systems and Design*.
- Entegro Energy Systems. (2024). *Entegro Energy Systems*. <https://entegro.com.tr/>
- Eşme, U. (2023). *Lecture notes*. Tarsus University, Faculty of Engineering.
- Ministry of National Education (MEB). (2022). *Renewable Energy Systems MEGEP modules*.
- Solarvizyon. (2023). *Solarvizyon*. <https://solarvizyon.org/>
- 123RF. (2024). *123RF*. <https://www.123rf.com>
- Durak, M., & Özer, S. (2012). *Solar Energy: Theory and Practice*.
- Phonosolar. (2024). *Phonosolar*. <http://www.phonosolar.com/>
- Smart Solar Technologies. (2024). *Smart Solar Technologies*. <https://www.smartsolar.com.tr/>
- Öztürk, A., & Dursun, M. (2011). *Design of 2, 10, and 20 KVA photovoltaic systems*. Düzce University.
- Göktekin Energy. (2023). *Operation and maintenance checklist*.